



Information contained within this Section is based on standard industry practices and guidance found in the 2012 International Plumbing Code (IPC) Commentary and the Uniform Plumbing Code (UPC), Appendix H. Size, type, and installation of Interceptors shall be in accordance with the manufacturer's instructions and the Program. The term "Interceptor" shall mean a receptacle designed and constructed to intercept, separate and prevent passage of grease, oil, fats, sand, grit, lint, or other objectionable solids into the SJRA collection system to which it is connected. An Interceptor may be integrated with a separator for vehicle wash bays or repair areas.

- A. The requirements outlined in these guidelines shall be considered minimum requirements only. It shall be the responsibility of each Generator to have an Interceptor installed and maintained that will produce an effluent in compliance with the requirements of the Program or more stringent Federal or State regulations.
- B. Existing Generators that, as a result of an expansion or a change in business use, are required to maintain an Interceptor not equipped with the required device(s) for the type of business or an inadequately sized Interceptor, shall install the required and adequately-sized Interceptor in accordance with this Program, if instructed to do so by SJRA. Subject to SJRA's discretion, existing Generators that have not expanded or changed business use may not be required to comply with this subsection (b).
- C. Plans for new Interceptors or modifications to existing Interceptors shall be submitted to the SJRA, prior to the purchase and installation of such devices.
  - 1) A description of and number of plumbing fixtures draining to the Interceptor, seating capacity, days & hours of operation, along with a menu shall be included in the submittal for all food service establishments.
- D. An existing Interceptor which is upgraded or replaced shall meet or exceed the specifications set forth in the Program and other applicable Local, State, or Federal requirements.
- E. Generators are responsible for maintaining their Interceptor in continuous proper working condition.
- F. (1) SJRA shall approve of the final plans prior to the issuance of any required plumbing or construction permits and subsequent construction. (2) Generators must provide SJRA with written evidence of an approved plumbing inspection of the interceptor before discharging into the collection system.
- G. Interceptors or any other equipment used to meet the Program requirements from Generators shall be designed and sealed by a licensed TX Professional Engineer in good

standing. The design shall meet all requirements as set in this Program and/or Federal or state regulations if more stringent or required.

- H. Interceptors can be installed by a contractor, however all plumbing work must be performed by a TX licensed plumber, in good standing. Completed Interceptor must be inspected by the SJRA prior to connecting to the sanitary sewer collection system. For new installations, inspections will be conducted a minimum of one (1) or more times as necessary during the installation.
- I. Interceptors shall be installed outside the building wherever possible. Where it is impossible to locate an Interceptor outside the building, the Interceptor shall be located in a mechanical room or other separate area where no food is stored or processed. The interceptor can only be installed inside of the building if approval by SJRA is received.
- J. Interceptors shall be located so as to be readily and easily accessible for cleaning and inspection of the Interceptor and shall be equipped with easily removable covers.
- K. Manhole rings and covers (metal) shall not be less than twenty-four (24) inches in diameter. Lids must be installed at floor or above floor level, but not below finished grade, to prevent infiltration. Manhole lids shall be installed for each compartment with riser rings, if needed, so that all internal piping is accessible for maintenance and inspection. The riser rings must be installed per industry standard and shall be sealed between each riser ring through the use of a mastic or grout. The inside of the riser rings will be grouted smooth to assist in preventing infiltration.
- L. Interceptors shall have a total liquid capacity of not less than seven hundred fifty (750) gallons. Interceptors shall be constructed with a minimum of two compartments. Unless Interceptor design criteria qualifies/calculates for the need of an alternative size as indicated on letter (r) of this section. At its discretion, SJRA may grant a variance to this requirement upon Generator's written demonstration of need.
- M. Interceptors shall consist of a one (1) tank, two compartments constructed of impervious materials capable of withstanding abrupt and extreme changes in temperature and capable of withstanding the traffic load where installed. Concrete used to build Interceptors or parts of it shall have a minimum of 4,000 psi.
- N. Commercial dishwashers are discharged through an Interceptor, therefore care must be taken when system design/Interceptor size is calculated. Dishwashers use detergents and elevated water temperatures that will melt grease. If the Interceptor is either too small or too close to the commercial dishwasher, grease may pass through the Interceptor and into the collection system.
- O. All liquid waste lines in food preparation areas such as dishwashing, garbage disposal, soft



- a. Fully equipped commercial kitchen
  - i. 8 hour operation 1
  - ii. 16 hour operation 2
  - iii. 24 hour operation 3

- b. Single Service Kitchen\* 1.5

*\*Single Service Kitchen. A food service establishment where no food is cooked, they only heat (microwave) and serve food using paper service items.*

**Method 2: Five (5) Hour Detention/Peak Flow**

- A. Gallons of water used per hour of operation:
- B.  $A \times 0.75$  = average “gray water” flow per hour
- C.  $B \times 1.9$  peak flow factor
- D.  $C \times 5$  hours detention = volume of Interceptor

Required volume of Interceptor =  $A \times B \times C \times D$

R. *Alternate Sizing Formula / Proposal:* Food service establishments that propose the use of alternate sizing techniques and/or procedures that result in calculations of less than the minimum specification requirements (or are less than the MINIMUM 750 gallon sized requirement, i.e. food service establishments such as sandwich shops) must submit formulas and other basis to support proposed Interceptor size/ installation. Submission should also provide documentation of ability to meet Program requirements. This proposal must be signed by a TX licensed plumbing contractor (master plumber), in good standing, or TX Professional Engineer, in good standing, and must include calculations and justification for non-standard installation. Proposals shall be approved on an individual basis.

- 1) In no cases will an alternate sized Interceptor be accepted that is less than 100 gallon capacity.

S. Construction/Installation of Interceptors must meet the following installation conditions:

- 1) The primary chamber shall contain three-fourths (3/4) of the total liquid capacity of the Interceptor. Interceptors shall have a complete separate ventilation system, (not to be combined with building ventilation) see Figure 4. An alternate Interceptor chamber configuration can be utilized provided that the design detention times/parameters are met and the Interceptor configuration is submitted and approved by SJRA.
- 2) The dividing wall between each chamber shall completely divide the chambers (shall extend top to bottom). Each compartment on an Interceptor shall have a vent (refer to Figure 2 and 3)

- 3) The effluent leaving the Interceptor shall not have total oil, grease, BOD, TSS concentration, as determined by proper laboratory analytical methods, in excess of the discharge limits specified in SJRA Surcharge Order.
  - i. The local surcharge limit for BOD is 200 mg/l. There is no prohibition limit for BOD; however, any amount discharged above the surcharge limit may be assessed through the local Surcharge Order.
  - ii. The local surcharge limit for TSS is 220 mg/l. There is no prohibition limit for TSS; however, any amount discharged above the surcharge limit may be assessed through the local Surcharge Order.
- 4) Interceptors shall be equipped with cleanouts on the outside of the Interceptors in both the influent (prior to the Interceptor) and effluent (after the Interceptor) pipes and cleanout on service line at the property line. \*Inlet and Outlet lines must not hold any water once flow to the Interceptor has ceased. Also cleanouts shall be installed at floor level in a way as to prevent infiltration into the sanitary sewer or into the Interceptors. Interceptor compartment vents shall have cleanouts installed for ease of maintenance, refer to Figure 4.
- 5) Outlet cleanout/sample port on effluent line of Interceptor shall be no less than 3' (feet) and no more than 5' (feet) apart from Interceptor. (Sample port on effluent line must be a straight "T" and shall not hold water after flow to the Interceptor has ceased).
- 6) The influent shall enter each chamber below the static water level in accordance with the specifications outlined in this paragraph. The effluent shall discharge from below the static water level of the chamber in accordance with the specifications outlined in this paragraph.
- 7) Baffle pipe is required to be 24" inch to 36 inch separation between baffle pipe and outlet line. If necessary the baffle pipe, outlet line or both may be offset to achieve the required 24" to 36" separation.
- 8) All plumbing inside the Interceptor shall be schedule 40 PVC
- 9) The sampling port is to be PVC
- 10) The influent line into all chambers shall terminate no greater than twenty four (24) inches from the bottom of the chamber.
- 11) The effluent from all chambers shall discharge from the lower eighteen (18) inches of the chamber.
- 12) Additional tanks (when placed in series) will consist of PVC pipe installed at a 45° angle.
- 13) Interceptors must to be installed wall to wall interconnecting with a PVC pipe, installed at a 45° degree angle, please refer to Figure(s) 2 and 3 for typical Interceptor (layout or design).
- 14) The static water level shall be maintained throughout the entire Interceptor(s).
- 15) All permitting, construction, and inspection activities must be completed in accordance with the Program. Additionally, the following specifications must be incorporated into Interceptor design.

- i. The Interceptor shall be constructed with only one baffle.
- ii. Interceptors are to be installed at a minimum distance of 10 ft. from sinks and dishwashers to allow for adequate cooling of the wastewater. Water temperatures must be less than 120 degrees prior to entering Interceptor.
- iii. All grease bearing waste streams must be routed through an appropriate Interceptor, including: three-compartment sinks, pot/pan sinks, soup kettles, hand-washing sinks, dishwashers, mop sinks, bar areas and floor drains. *Notable Exceptions:* Drains that receive “clear waste” only, such as from ice machines, condensate from coils, may be plumbed to the sanitary system without passing through the Interceptor with the condition that the receiving drain is a “hub” type that is a minimum of two inches above the finished floor.
- iv. Upon the completion of construction and installation of the Interceptor all such facilities shall be clean of debris prior to inspection by SJRA.

- T. Variance Procedure. A Generator may request a variance from any requirements of these guidelines. A request for variance may be made in writing to SJRA and must include a description of the request and all supporting information necessary for SJRA to make a determination. SJRA may grant the variance to the requirement(s) identified in the Generator's variance request at its discretion.

## **OTHER TYPES OF INTERCEPTORS AND SIZING REQUIREMENTS**

Interceptors are required for oil, grease, sand and other substances harmful or hazardous to the collection system or wastewater treatment plant. Design, size, and location of Interceptors must be submitted to SJRA for review and approval by a TX licensed plumbing contractor or TX Professional Engineer, in good standing, for review and approval.

### **Laundries**

Commercial Laundries, Laundromats, and dry-cleaners shall be equipped with an Interceptor in order to reduce the quantity of lint and silt that enter the collection system. The system must be of adequate size and design to allow for cool-down of wastewater so that separation can be more readily achieved. The Interceptor must be installed with a wire basket or similar device, removable for cleaning, that prevents passage into the collection system of solids ½ inch (12.7 mm) or larger in size, string, rags, buttons or other materials detrimental to the public sewerage system.

Sizing must be in accordance with guidance found in the Uniform Plumbing Code (UPC), Appendix H which uses the following formula:

$$(TGC) \times (CPH) \times (RT) \times (ST) = \text{Size of Lint Interceptor (gallons)}$$

Where:

- TGC = Total Gallons per Cycle
- CPH = Cycles per hour
- RT = Retention time
  - 2.5 For Institutional Laundry
  - 2.0 For Standard Commercial Laundry
  - 1.5 For Light Commercial Laundry
- ST = Storage Factor, based on hours of operation;
  - For 8 hours of operation
  - For 12 or more hours

### **Car Washes**

Where automobiles are washed (including detail shops utilizing hand- wash practices), Interceptors shall have a minimum capacity of 1000 gallons for the first bay, and 500 gallons of capacity for every additional bay.



Each wash bay on a car wash should have a mud trap in place. Mud trap shall have a minimum capacity of 300 gallon and shall be connected to an Interceptor.

### **Automotive Repair Facilities (Garages and Service Stations)**

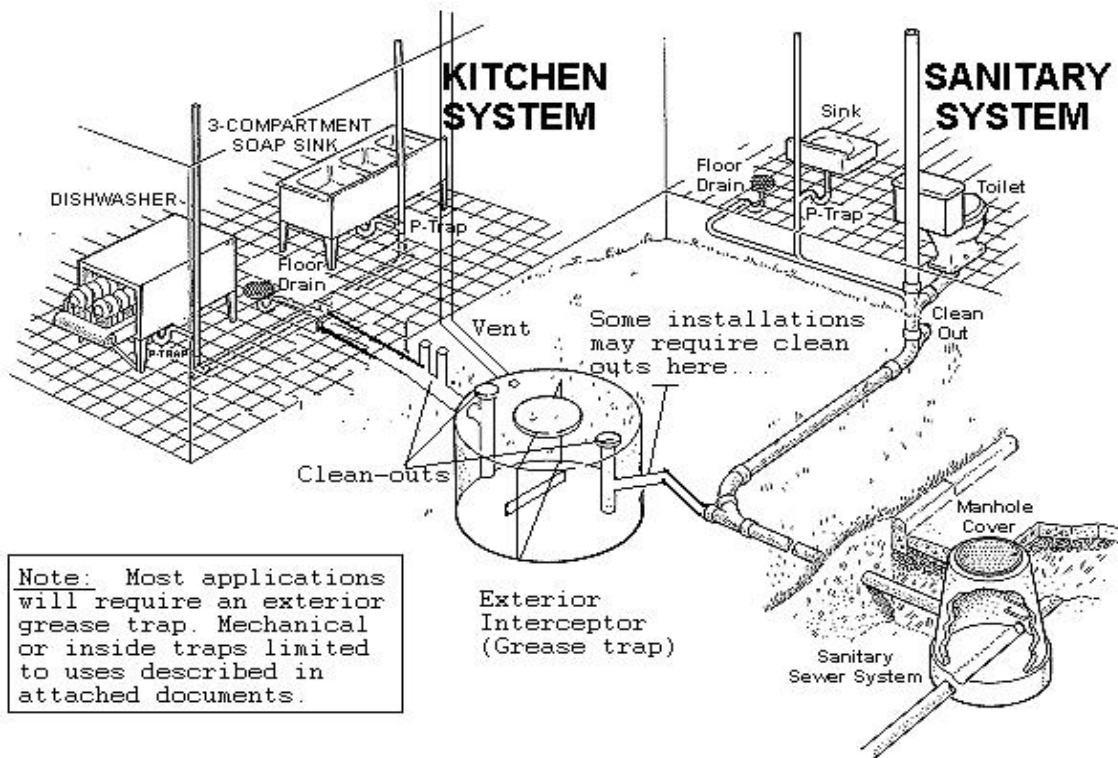
Work areas of machine shops or of any facility or part of a facility which manufactures, rebuilds, repairs, overhauls, or maintains motors, transmissions, hydraulic systems, or similar machinery and areas where fluids are changed shall not discharge wastewater other than domestic waste (restrooms) into the sanitary sewer.

Work areas of machine shops or of any facility or part of a facility which manufactures, rebuilds, repairs, overhauls, or maintains motors, transmissions, hydraulic systems, or similar machinery and areas where fluids are changed shall not have floor drains or other devices draining into the sanitary sewer. Wastewater from automobile parts washing, cleaning machinery, or machinery parts shall be not be discharged to the system.

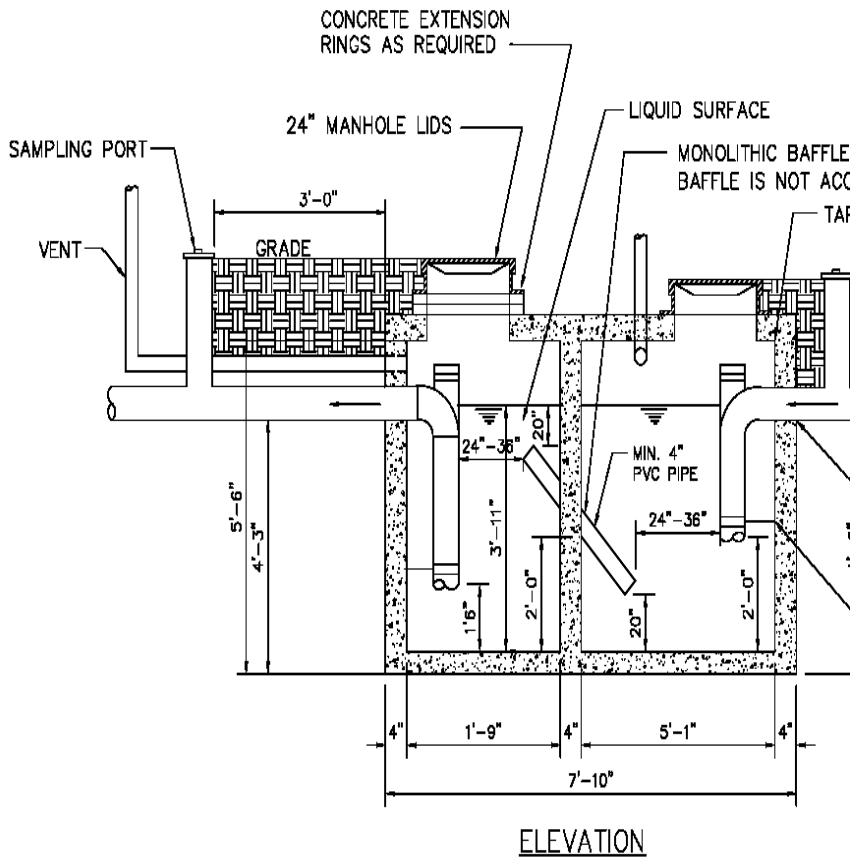
As set on the following Federal, State and local regulations no discharge of petroleum or petroleum byproducts shall be discharge into the sanitary sewer.

- a) 40 CFR Code of Federal Regulations § 403.5 National pretreatment standards: Prohibited discharges:
  - 1) *Specific prohibitions.* In addition, the following pollutants shall not be introduced into the sanitary sewer system:
    - i. Pollutants which create a fire or explosion hazard in the sanitary sewer system, including, but not limited to, waste streams with a closed cup flashpoint of less than 140 degrees Fahrenheit or 60 degrees Centigrade using the test methods specified in 40 CFR 261.21;

**Figure 1 - Typical Plumbing Layout**

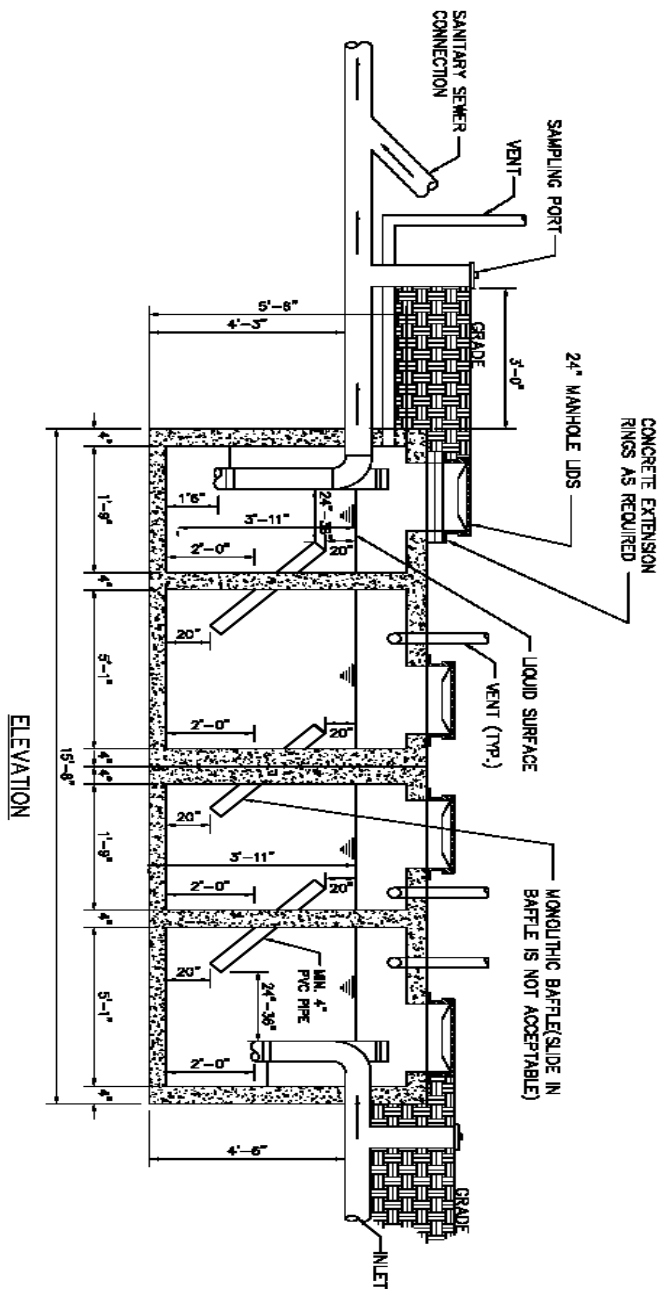


**Figure 2 - Typical Interceptor Schematic**



NOTE: Second compartment length shown is less than 24" inches. Baffle pipe was offset to achieve the required 24" inch to 36 inch separation between baffle pipe and outlet line. If necessary the baffle pipe, outlet line or both may be offset to achieve the required 24" to 36" separation.

Figure 3 - Multiple Interceptors Connected in Series Schematic



NOTE: Second compartment length shown is less than 24" inches. Baffle pipe was offset to achieve the required 24" inch to 36 inch separation between baffle pipe and outlet line. If necessary the baffle pipe, outlet line or both may be offset to achieve the required 24" to 36" separation.

Figure 4 - Pretreatment Device Ventilation System Schematic

